



Flow switch

For liquids in piping DN 10...25

QVE1902.010
QVE1902.015
QVE1902.020
QVE1902.025

-
- **Contact load: max. AC 230 V, 1 A, 26 VA
DC 48 V, 1 A, 20 W**
 - **Nominal pressure PN10**
 - **Manual contact setting (NO/NC contact)**
 - **Housing protection type IP 65 / Protection class II**
 - **Maintenance free**

Use

In HVAC plants to monitor the flow of liquid medium in hydraulic systems, in particular, refrigeration, heat pump and heating plants, e.g. for evaporators, boilers, heat exchangers, etc.

Type summary

| Type / ASN | Product number (SSN) | Name |
|-------------|----------------------|-------------|
| QVE1902.010 | S55720-S199 | Flow switch |
| QVE1902.015 | S55720-S200 | Flow switch |
| QVE1902.020 | S55720-S201 | Flow switch |
| QVE1902.025 | S55720-S202 | Flow switch |

Ordering

When ordering, please specify the quantity, type, and product name.

Sizing

Switching value table for water at 20 °C

| Type (ASN) | DN | Threading [inch] | Q _{max} [l/min] | Factory setting (range) [l/min] | | |
|-------------|-------|------------------|--------------------------|---------------------------------|-------------------|--------------------|
| | | | | ↔ | ↑ | ↓ |
| QVE1902.010 | DN 10 | 3/8 | 20 | 3.2 (2.8...3.7) | 2.7 (2.0...3.4) | 3.6 (3.1...4.1) |
| QVE1902.015 | DN 15 | 1/2 | 30 | 4.2 (3.6...4.9) | 3.4 (2.8...4.0) | 4.4 (3.7...5.1) |
| QVE1902.020 | DN 20 | 3/4 | 80 | 7.6 (6.9...8.4) | 7.1 (6.1...8.2) | 8.7 (8.0...9.5) |
| QVE1902.025 | DN 25 | 1 | 130 | 12.0 (10.8...13.3) | 10.5 (8.9...12.1) | 13.1 (12.0...14.3) |

Engineering notes

Warning

- The flow switch QVE1902.0xx is not a safety component in terms of Directive 2006-42-EC.
- Operational safety of the supplied device is only guaranteed when used properly (monitoring the flow of liquids). Under no circumstances may the indicated limit values (see "Technical data") be exceeded.
- You must ensure that the materials used in the flow switch are sufficiently chemically and mechanically durable against the medium to be monitored as well as external influences.

Caution

- Comply with maximum contact load for the reed contact. The maximum contact load indicated on the type label applies to Ohm loads only and may not be exceeded under any circumstances.
High voltage or current spikes may occur when switching, in particular, inductive or capacitive loads (e.g. relay coils, capacitors). Even a short overload may destroy (fusing of contacts) or damage (reduced life cycle) reed contacts. Use appropriate and tested safety measures.
- Select suitable measures to prevent the medium from freezing.
Do not operate, e.g. testing, the flow switch using pure water if operated in ambient temperatures of <4°C. Residual water in the flow switch may result in frost damage.

Mounting instructions

- A smoothing section of at least 10 x or 5 x the pipe diameter respectively must be planned prior to and after intended location.
- First, clean the pipe system where the flow switch is installed and remove any magnetic particles, e.g. welding residue.
- Do not use grease or oils to seal the flow switch or its piping.

Orientation

- horizontal, at a maximum angle of 45°, as well as
- vertical

See illustration below

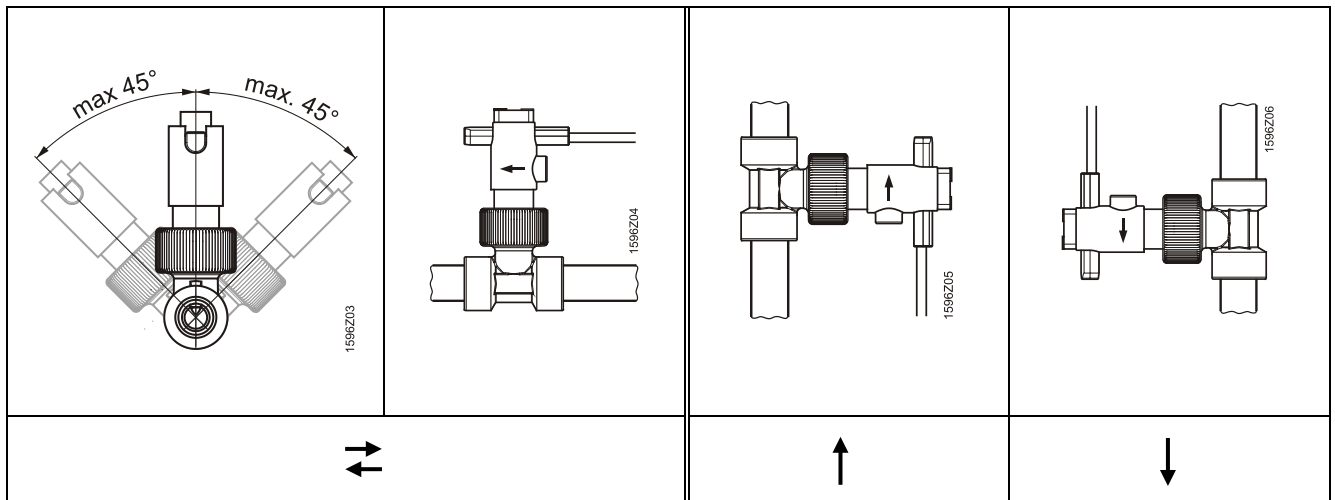

- Ensure when mounting that the arrow points parallel to the pipe axis and indicates the direction of flow.
- Install the section of piping for the flow switch the same as a valve in the existing piping.

Installation notes

- Comply with all local regulations on electrical systems.
- Only qualified personnel may do the electrical installation.
- Always de-energize the system before connecting the wires of the mains cable.
- The connecting cable to relieve tension has a reserve loop so that there is sufficient "play (cable)" when making fine adjustments to the switching unit.

Commissioning notes

Contact type factory setting

The switching unit is factory set as a make contact, i.e. the reed contact opens if the set switching point is breached.

NO or NC contact

| Type of contact | Setting | Flow rate | Electric contact |
|-----------------|-------------|------------|------------------|
| NO (closer) | RED arrow | increasing | closing |
| | | decreasing | opening |
| NC (opener) | WHITE arrow | increasing | opening |
| | | decreasing | closing |

Setting the switching unit

The setting can be changed as needed by the customer:

- Loosen the locking screw (Phillips-head screw) and position the switching unit until the red or white arrow are visible at the entry of the switching contact guide for a desired normally open (NO) or normally closed (NC) contact respectively.
- You can use the arrow length to make fine adjustments to the switching point: Adjust to the arrowhead means: Switching point is at a lower flow rate. Adjust to the arrow end: Switching point is at a higher flow rate.
- Carefully retighten the locking screw.
- We recommend using thread locker to secure the locking screw on the switching unit after carrying out individual adjustments.

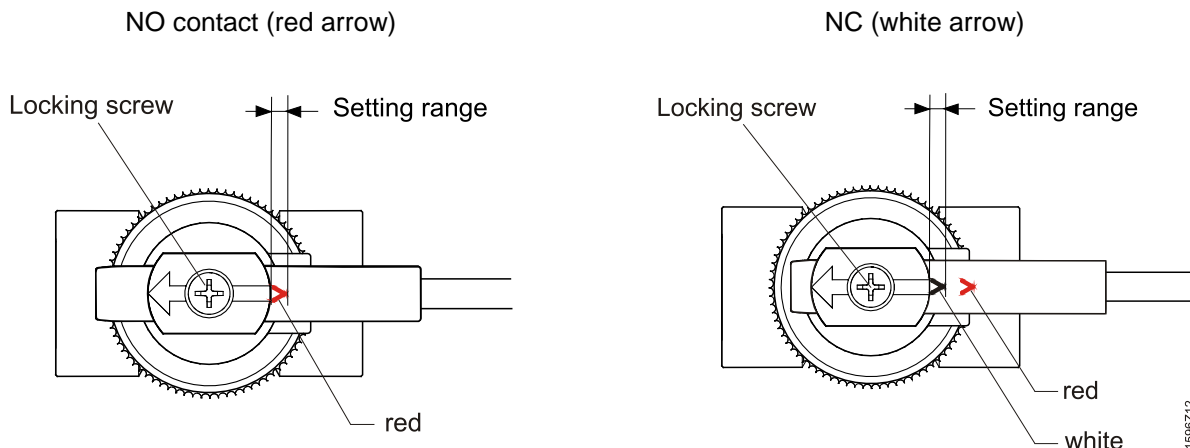

Operating notes

- Please make sure that there are no external magnetic fields in the immediate vicinity of the flow switch, since these can impair device operation.
- Ensure that the maximum operating pressure is not exceeded.

Service notes

- Never remove a flow switch or its body from a system under pressure.
- The flow switch is maintenance-free and cannot be repaired by the user.

Disposal



The devices are considered electronics devices for disposal in terms of European Directive 2012/19/EU and may not be disposed of as domestic waste.

- Dispose of the device via the channels provided for this purpose.
- Comply with all local and currently applicable laws and regulations.

Technical data

| | | |
|--------------------------------|--|---|
| Functional data general | Field of use | All liquids |
| | Permissible media | (not suitable for ammonia) |
| | Medium temperature | -20...100 °C (Medium may not freeze) |
| | Piping diameter | DN 10...25 |
| Switching function | Nominal pressure | PN 10 (piping approved for PN 25) |
| | Contact | Closes as flow increases ^{*)} Opens as flow decreases ^{*)} |
| | Type of switch | Reed contact |
| | Max. contact rating | AC 230 V, 1 A / DC 48 V, 1 A |
| | Max. switching capacity | 26 VA or 20 W |
| | Length of connecting cable/cross section | 1.5 m / 0.5 mm ² |
| | External supply line protection (EU) | Fuse slow max. 10 A or Circuit breaker max. 13 A Characteristic B, C, D according to or Power source with current limitation of max. 10 A |
| | Switching point adjustment | Manual, set at the factory to the middle of the setting range |
| | Setting range | See Sizing on page 2 |
| | Degree of protection | Protection class |
| Housing | | IP65 according to EN 60529 |
| Environmental conditions | Storage, transportation, operation | |
| | Temperature | 0...70 °C |
| | Humidity | <95 % r.h. |
| Standards and Directives | Product standard | EN 60204-1 Safety of machinery - Electrical equipment of machines |
| | EU Conformity (CE) | CM1T1596xx ^{**)} |
| Environmental compatibility | The product environmental declaration CE1E1596 ^{**)} contains data on environmentally compatible product design and assessments (RoHS compliance, materials composition, packaging, environmental benefit, disposal). | |
| Dimensions / Weight | Excl. packaging | See under "Dimensions and weight" |
| Material | Switching unit/connecting cable | Polyamide / PVC |
| | Housing and paddle system/piping | PPO Noryl GFN3 / brass |
| Housing color | | Black |

^{*)} Applies to delivery state (switching function can be inverted as needed).

^{**)} The documents can be downloaded from <http://siemens.com/bt/download>.

Dimensions and weight

Dimensions in mm

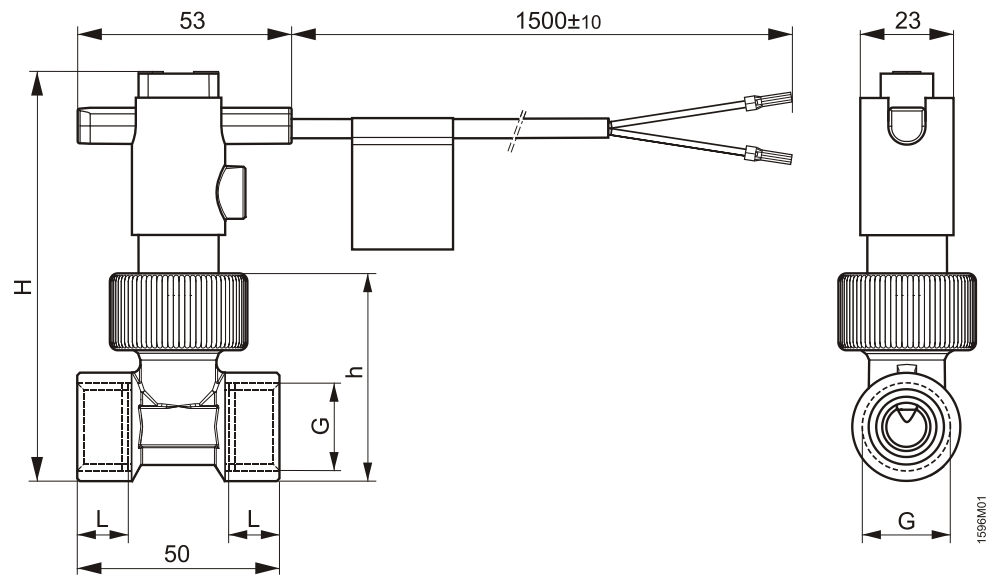

| Type (ASN) | Nominal width dia | Qmax [l/min] | G [inch] | L [mm] | h [mm] | H [mm] | Weight [g] |
|-------------|-------------------|--------------|-----------------|--------|--------|--------|------------|
| QVE1902.010 | DN 10 | 20 | G $\frac{3}{8}$ | 11 | 41.5 | 101.5 | 255 |
| QVE1902.015 | DN 15 | 30 | G $\frac{1}{2}$ | 11 | 41.5 | 101.5 | 220 |
| QVE1902.020 | DN 20 | 80 | G $\frac{3}{4}$ | 15 | 46.0 | 105.5 | 239 |
| QVE1902.025 | DN 25 | 130 | G1 | 15 | 55.5 | 115.5 | 315 |